

顶出砂缸分解图

STRUCTURE CHART FOR TOP-MOUNTED SAND FILTER

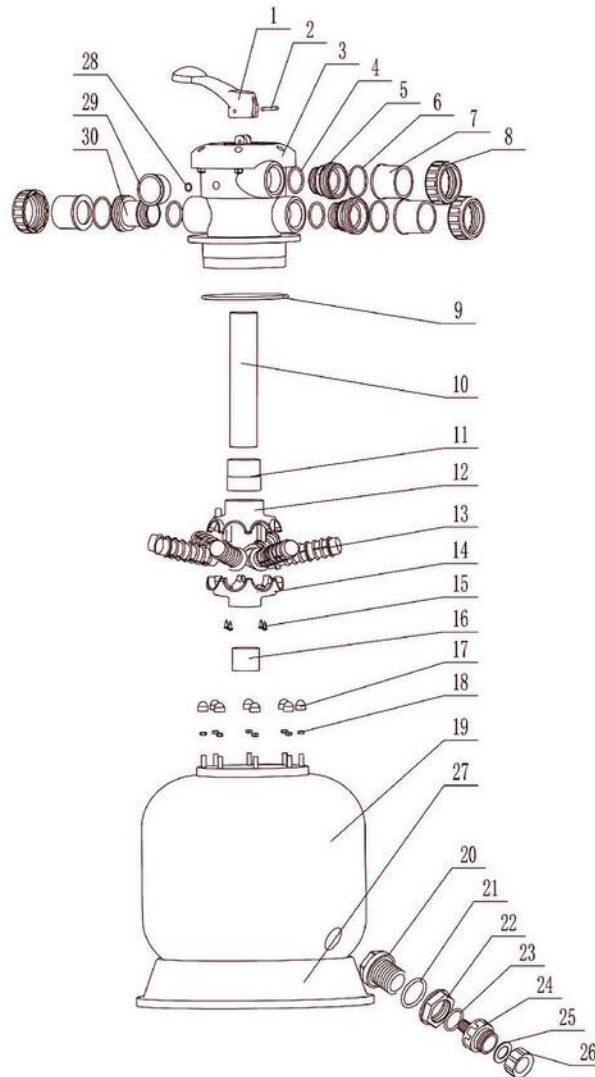

序号	名称	Discription	序号	名称	Discription	序号	名称	Discription
1	手柄	Handle	11	变径接头	Adapter	21	O型圈	O Ring
2	销钉	Pin	12	过滤管座(上)	Filter tube socket	22	六角螺母	Hexagon nut
3	多功能阀	Multi-functional vavle	13	过滤管	Filter tube	23	O型圈	O Ring
4	O型圈	O Ring	14	过滤管座(下)	Filter tube socket	24	阀芯	Valve insert
5	螺纹接管	Thread union	15	自攻螺钉	Tapping socket	25	O型圈	O Ring
6	O型圈	O Ring	16	pvc管	PVC pipe	26	螺盖	Screw lid
7	接管	Tie	17	装饰帽	Nut cover	27	底座	Filter stand support
8	固定螺母	Tie in nut	18	螺母	Nut	28	O型圈	O Ring
9	O型圈	O Ring	19	缸体	Filter tank	29	压力表	Pressure gauge
10	PVC管	PVC pipe	20	排水阀主体	Drainage union	30	透明接管	Transparent pipe